

# Катки гладильно-сушильные П10-55.

## Технические характеристики.



Архангельск (8182)63-90-72  
Астана (7172)727-132  
Астрахань (8512)99-46-04  
Барнаул (3852)73-04-60  
Белгород (4722)40-23-64  
Брянск (4832)59-03-52  
Владивосток (423)249-28-31  
Волгоград (844)278-03-48  
Вологда (8172)26-41-59  
Воронеж (473)204-51-73  
Екатеринбург (343)384-55-89  
Иваново (4932)77-34-06

Ижевск (3412)26-03-58  
Иркутск (395)279-98-46  
Казань (843)206-01-48  
Калининград (4012)72-03-81  
Калуга (4842)92-23-67  
Кемерово (3842)65-04-62  
Киров (8332)68-02-04  
Краснодар (861)203-40-90  
Красноярск (391)204-63-61  
Курск (4712)77-13-04  
Липецк (4742)52-20-81  
Киргизия (996)312-96-26-47

Магнитогорск (3519)55-03-13  
Москва (495)268-04-70  
Мурманск (8152)59-64-93  
Набережные Челны (8552)20-53-41  
Нижний Новгород (831)429-08-12  
Новокузнецк (3843)20-46-81  
Новосибирск (383)227-86-73  
Омск (3812)21-46-40  
Орел (4862)44-53-42  
Оренбург (3532)37-68-04  
Пенза (8412)22-31-16  
Казахстан (772)734-952-31

Пермь (342)205-81-47  
Ростов-на-Дону (863)308-18-15  
Рязань (4912)46-61-64  
Самара (846)206-03-16  
Санкт-Петербург (812)309-46-40  
Саратов (845)249-38-78  
Севастополь (8692)22-31-93  
Симферополь (3652)67-13-56  
Смоленск (4812)29-41-54  
Сочи (862)225-72-31  
Ставрополь (8652)20-65-13  
Таджикистан (992)427-82-92-69

Сургут (3462)77-98-35  
Тверь (4822)63-31-35  
Томск (3822)98-41-53  
Тула (4872)74-02-29  
Тюмень (3452)66-21-18  
Ульяновск (8422)24-23-59  
Уфа (347)229-48-12  
Хабаровск (4212)92-98-04  
Челябинск (351)202-03-61  
Череповец (8202)49-02-64  
Ярославль (4852)69-52-93

Единый адрес для всех регионов: [hcs@nt-rt.ru](mailto:hcs@nt-rt.ru) || [www.huebsch.nt-rt.ru](http://www.huebsch.nt-rt.ru)

## On-Premises I10 Heated Roll Ironer

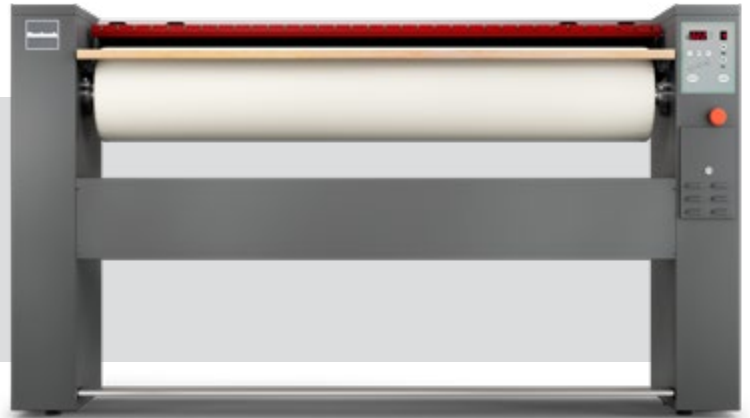

When only the highest quality results will do, our heat-ed-cylinder finishers deliver. They are equipped with a frequency-controlled motor, suspended roll and Nomex® ironing belts to deliver top-of-the-industry results.

### Quality

Huebsch Heated Roll Ironers are offered in finished widths of 55 (1400 mm), 66 (1664 mm), 79 (2000 mm), 82 (2080 mm), 102 (2600 mm) and 126 (3200 mm) inches meaning there's a size to fit the needs of any size laundry.

### Efficient

Thick, polished-steel cylinders maintain even heat and help make the finishers highly efficient. A totally enclosed cabinet also contributes to its energy efficiency.



### Microprocessor Control

Huebsch's versatile Microprocessor Control enables you to store temperature and speed settings to ensure consistent, top-quality results. Temperatures can be set up to 355°F and the unit offers multiple speed settings.

## On-Premises I10 Heated Roll Ironer Specifications

SPECIFICATIONS		
MODEL	I10-55	
AVAILABLE CONTROL	Microprocessor	
ROLL DIAMETER - in (mm)	10 (254)	
FINISHING WIDTH - in (mm)	55 (1400)	
IRONING SPEED - ft/m (m/m)	7-13 (2-4)	
IRONER DIMENSIONS (working position) - in (mm)	Width	70 7/8 (1800)
	Depth	16 1/2 (420)
	Height	39 5/8 (1005)
ROLL MOTOR - HP (kw)	0.29 (0.215)	
ROLL EXHAUST DUCT - in (mm)	2.17 (55)	
E Heat Input Power - HP (kW)	11.3 (8.4)	
ELECTRIC HEATING	Electric Requirements - Circuit Breaker	230/60/3 - 25
SHIPPING DIMENSIONS APPROX. - in (mm)	Width	45 1/4 (1150)
	Depth	74 (1880)
	Height	19 11/16 (500)
NET WEIGHT - lb (kg)	328 (149)	
SHIPPING WEIGHT - lb (kg)	287 (130)	
AGENCY APPROVALS	ETL	

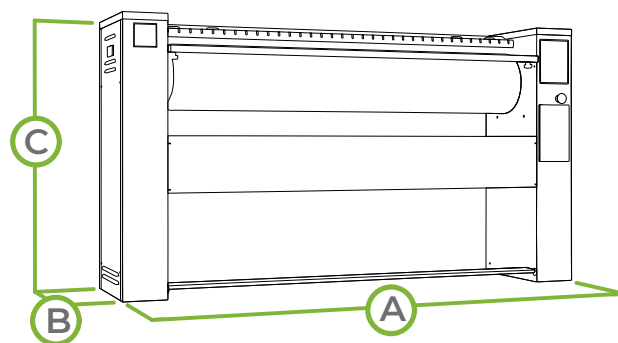

DIMENSIONS	
A. OVERALL WIDTH - in (mm)	70 7/8 (1800)
B. OVERALL DEPTH - in (mm)	16 1/2 (420)
C. OVERALL HEIGHT - in (mm)	39 5/8 (1005)

For the most accurate information, the installation guide should be used for all design and construction purposes. Due to continuous product improvements, design and specifications subject to change without notice. The quality management system of Alliance Laundry Systems has been registered to ISO 9001.

Архангельск (8182)63-90-72  
 Астана (7172)727-132  
 Астрахань (8512)99-46-04  
 Барнаул (3852)73-04-60  
 Белгород (4722)40-23-64  
 Брянск (4832)59-03-52  
 Владивосток (423)249-28-31  
 Волгоград (844)278-03-48  
 Вологда (8172)26-41-59  
 Воронеж (473)204-51-73  
 Екатеринбург (343)384-55-89  
 Иваново (4932)77-34-06

Ижевск (3412)26-03-58  
 Иркутск (395)279-98-46  
 Казань (843)206-01-48  
 Калининград (4012)72-03-81  
 Калуга (4842)92-23-67  
 Кемерово (3842)65-04-62  
 Киров (8332)68-02-04  
 Краснодар (861)203-40-90  
 Красноярск (391)204-63-61  
 Курск (4712)77-13-04  
 Липецк (4742)52-20-81  
 Киргизия (996)312-96-26-47

Магнитогорск (3519)55-03-13  
 Москва (495)268-04-70  
 Мурманск (8152)59-64-93  
 Набережные Челны (8552)20-53-41  
 Нижний Новгород (831)429-08-12  
 Новокузнецк (3843)20-46-81  
 Новосибирск (383)227-86-73  
 Омск (3812)21-46-40  
 Орел (4862)44-53-42  
 Оренбург (3532)37-68-04  
 Пенза (8412)22-31-16  
 Казахстан (772)734-952-31

Пермь (342)205-81-47  
 Ростов-на-Дону (863)308-18-15  
 Рязань (4912)46-61-64  
 Самара (846)206-03-16  
 Санкт-Петербург (812)309-46-40  
 Саратов (845)249-38-78  
 Севастополь (8692)22-31-93  
 Симферополь (3652)67-13-56  
 Смоленск (4812)29-41-54  
 Сочи (862)225-72-31  
 Ставрополь (8652)20-65-13  
 Таджикистан (992)427-82-92-69

Сургут (3462)77-98-35  
 Тверь (4822)63-31-35  
 Томск (3822)98-41-53  
 Тула (4872)74-02-29  
 Тюмень (3452)66-21-18  
 Ульяновск (8422)24-23-59  
 Уфа (347)229-48-12  
 Хабаровск (4212)92-98-04  
 Челябинск (351)202-03-61  
 Череповец (8202)49-02-64  
 Ярославль (4852)69-52-93